

Small Display Unit For Vivid Display (W11×H22mm) And Various 60 Characters And Signs

■ Features

- Displays 60 types of characters and signs (0 to 9, A to Z, 24 signs, dot)
- Selectable input logic (PNP/NPN), data input type (parallel/serial)
- 16 Segment in red/green
- Wide range of input signal level : Low: 0-1.2VDC, High: 4.5-24VDC
- 12-24VDC power supply
- Multi stage connection available

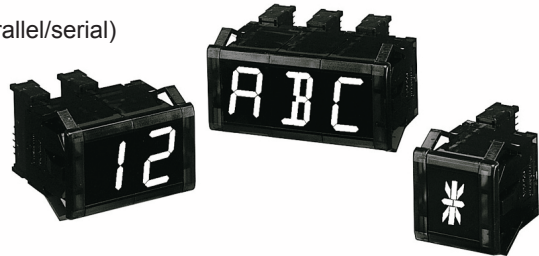

■ Applications

- Display for PLC
- Display for computer
- Various display

⚠ Please read "Caution for your safety" in operation manual before using.

■ Specifications

Model	D1AA-RN	D1AA-GN ^{※1}
Display method	16 Segment LED display (Red)	16 Segment LED display (Green)
Power supply	12-24VDC	
Allowable voltage range	90 to 110% of rated voltage	
Current consumption	Max. 32mA	
Display character	60 characters (0 to 9, A to Z, symbol (24 kinds), decimal point)	
Character size	W11×H22mm	
Input	•Parallel: Parallel 6-bit data, latch, decimal point •Serial: Serial 6-bit or 7-bit data, clock, latch, decimal point (for 6-bit input)	
Input level	High: 4.5-24VDC, Low: 0-1.2VDC	
Max. response CLOCK	Max. 3kHz	
Input resistance	20kΩ	
Output	Data output (Serial input)	
Input logic	Selectable and changeable positive (PNP) or negative (NPN) (By inner soldering)	
Noise strength	The square wave noise by simulator (pulse width:1μs) ±300V	
Environment	Ambient temperature	0 to 60°C, storage: -10 to 85°C
	Ambient humidity	35 to 85%RH
Sold separately	Connector	
Unit weight	Approx. 22g (including right/left caps)	

※1: This is option.

※The max. clock is when the duty ratio is 1:1.

※Environment resistance is rated at no freezing of condensation.

(A)	Photo-electric Sensors
(B)	Fiber Optic Sensors
(C)	Door/Area Sensors
(D)	Proximity Sensors
(E)	Pressure Sensors
(F)	Rotary Encoders
(G)	Connectors/ Sockets
(H)	Temperature Controllers
(I)	SSRs / Power Controllers
(J)	Counters
(K)	Timers
(L)	Panel Meters
(M)	Tacho / Speed / Pulse Meters
(N)	Display Units
(O)	Sensor Controllers
(P)	Switching Mode Power Supplies
(Q)	Stepper Motors & Drivers & Controllers
(R)	Graphic/ Logic Panels
(S)	Field Network Devices
(T)	Software

D1AA Series

Unit Description

① Function set switches

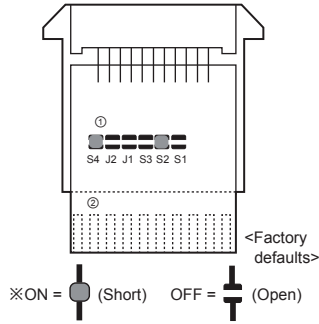

Switch	ON	OFF	Function
S1	—	—	Unused
S2	Parallel	Serial	Input
S3	4-bit	5-bit	Serial input
J1	Use	Unused	Serial data output ^{*1}
J2	—	—	Always set as OFF.
S4	Negative (NPN)	Positive (PNP)	Input logic

*1: For Serial input, set this as ON. For Parallel input, set this as OFF.

② Input/Output terminals

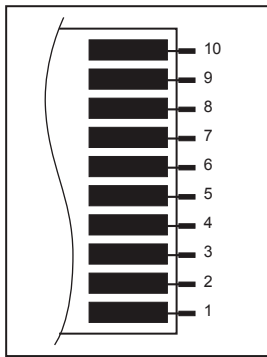

Terminal	Input		Serial input	
	Code	Function	Code	Function
1	VCC	12-24VDC	VCC	12-24VDC
2	D0	Data input	N·C	Do not connect anything.
3	D1		CK	Clock input
4	D2		DI	Data input
5	D3		DO	Data output
6	D4		N·C	Do not connect anything.
7	D5	N·C		
8	LE	Latch input	LE	Latch input
9	DP	Decimal point input	DP	Decimal point input
10	GND	0V	GND	0V

Block Diagram

③ Parallel input

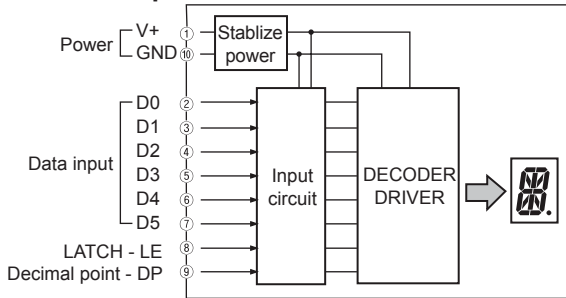

④ Serial input

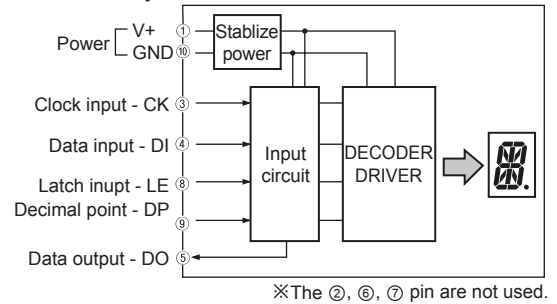

Dimensions

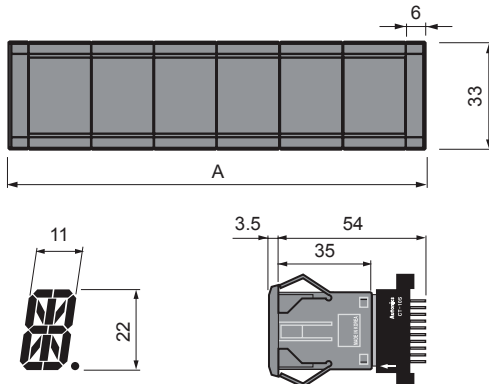

● Panel cut-out

(unit: mm)

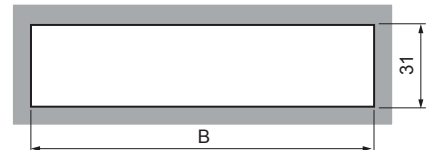

● Panel cut-out chart

Digit (N)	Dimension A (20×N+12)	Dimension B (20×N+10)
1	32	30±0.1
2	52	50±0.1
3	72	70±0.1
4	92	90±0.1
5	112	110±0.1
6	132	130±0.1
7	152	150±0.1
8	172	170±0.1

16 Segment Display Unit

○ Sold separately

- Connector (Model: CT-10S)

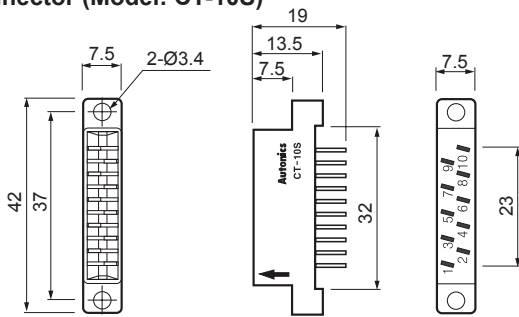

○ Accessory

- CAP



- D1AA-RN: DAR (L)-R (right/left 1 set)
- D1AA-GN: DAR (L)-BL (right/left 1 set)
- ※Cap is optional (1 set).

■ Input Data Chart

※In case of positive logic (PNP).

Upper 2-bit data (PNP type) in positive logic								Lower 4-bit data (PNP type) in positive logic			
D5	D4	D5	D4	D5	D4	D5	D4	D3	D2	D1	D0
L	L	L	H	H	L	H	H				
Blank		P		Blank		0		L	L	L	L
A		Q		Blank		1		L	L	L	H
B		R		"		2		L	L	H	L
C		S		⊗		3		L	L	H	H
D		T		\$		4		L	H	L	L
E		U		%		5		L	H	L	H
F		V		Blank		6		L	H	H	L
G		W		'		7		L	H	H	H
H		X		:		8		H	L	L	L
I		Y		:		9		H	L	L	H
J		Z		*		⊗		H	L	H	L
K		[+		⊗		H	L	H	H
L		\		⊗		⊗		H	H	L	L
M]		-		⊗		H	H	L	H
N		^		⊗		⊗		H	H	H	L
O		⊗		⊗		⊗		H	H	H	H

※Blank: Even though data is input as signal, it does not display.

■ Input Circuit

○ Positive logic (PNP) input

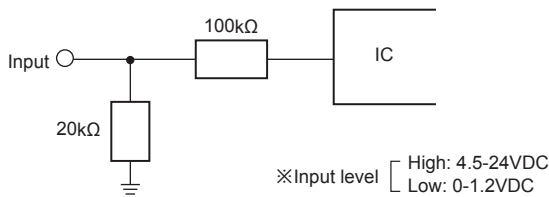

○ Negative logic (NPN) input

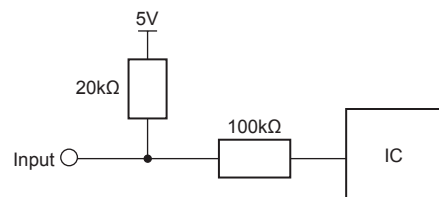

- (A) Photo-electric Sensors
- (B) Fiber Optic Sensors
- (C) Door/Area Sensors
- (D) Proximity Sensors
- (E) Pressure Sensors
- (F) Rotary Encoders
- (G) Connectors/ Sockets
- (H) Temperature Controllers
- (I) SSRs / Power Controllers
- (J) Counters
- (K) Timers
- (L) Panel Meters
- (M) Tacho / Speed / Pulse Meters
- (N) Display Units
- (O) Sensor Controllers
- (P) Switching Mode Power Supplies
- (Q) Stepper Motors & Drivers & Controllers
- (R) Graphic/ Logic Panels
- (S) Field Network Devices
- (T) Software

D1AA Series

■ Data Input Method

○ Parallel input

● 6-bit static parallel input (e.g.: displays Auto.)

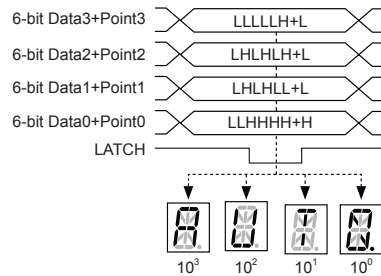
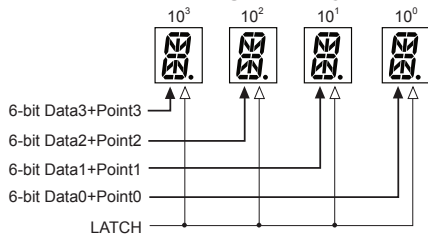

● 6-bit dynamic parallel input (e.g.: displays ACE007.)

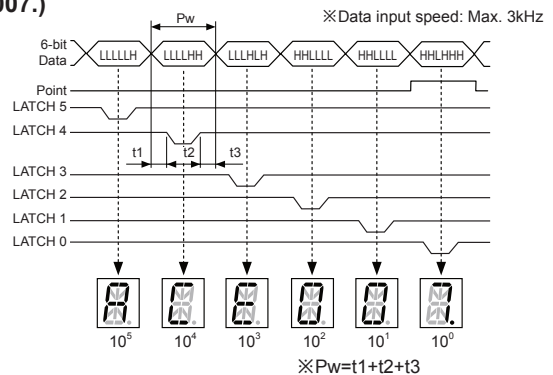
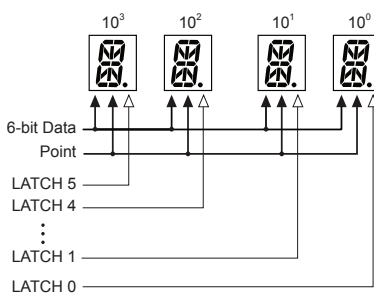

※Pw=t1+t2+t3

Pw: 0.33ms (Min.)

t1: 0.05ms (Min.) → Data LATCH

t2: 0.23ms (Min.) → Data move

t3: 0.05ms (Min.) → Data

○ Serial input

● 6-bit serial input (e.g.: displays -20.8)

※Clock: Max. 3kHz

※In case of positive logic (PNP), hexadecimal number

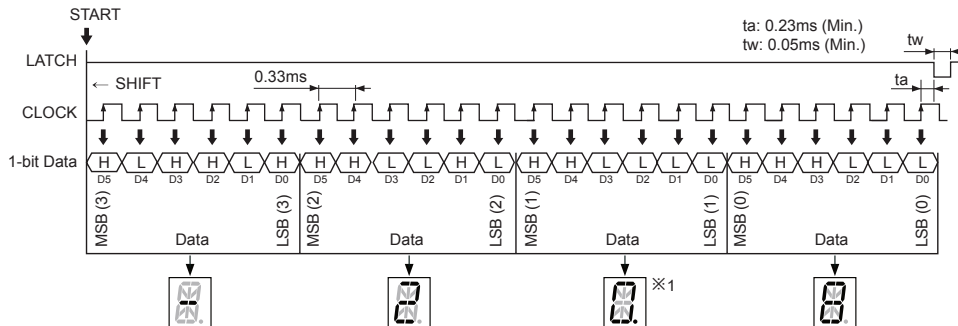

※1: For 6-bit Serial input, connect DP of rear input terminal to V+ to display decimal point.
In case of negative logic (NPN), connect DP to GND.

● 7-bit serial input (e.g.: displays AUTO.)

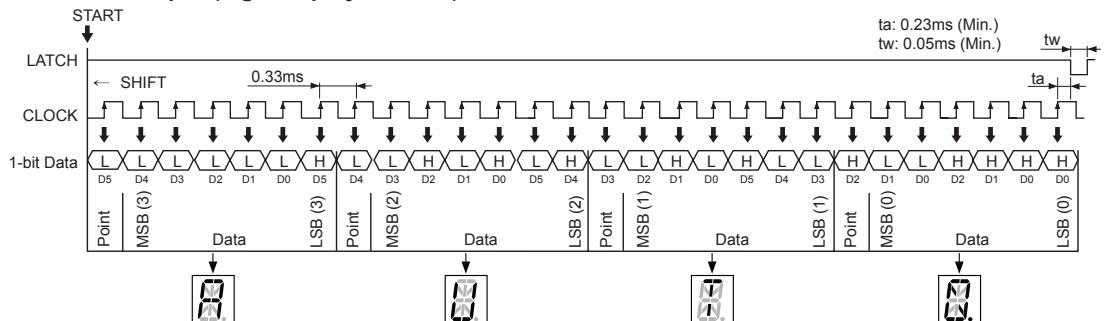

16 Segment Display Unit

■ Multi-Stage Connection Method

◎ Parallel input: 4digit

● Static parallel input (wiring at rear side of this unit)

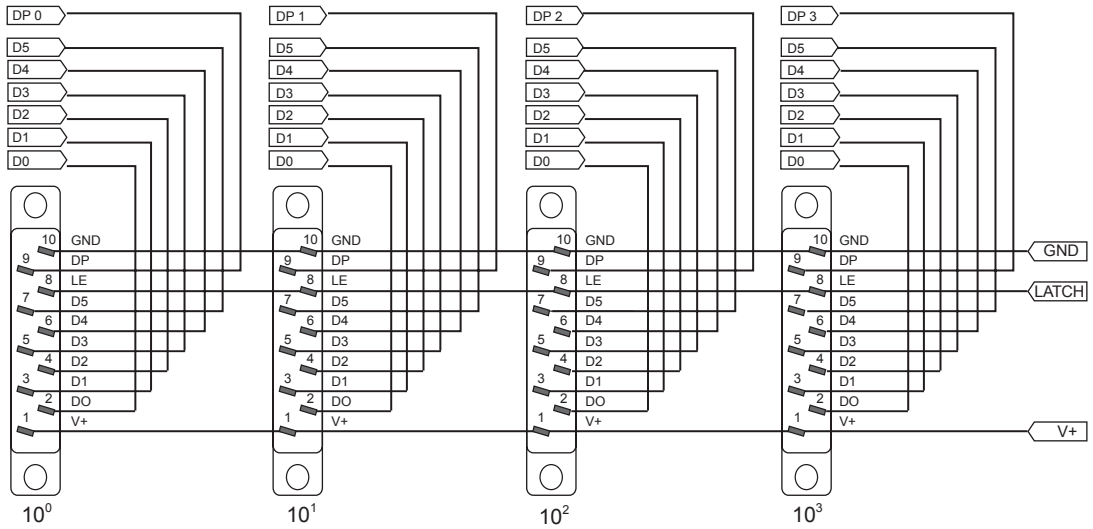

● Dynamic parallel input (wiring at rear side of this unit)

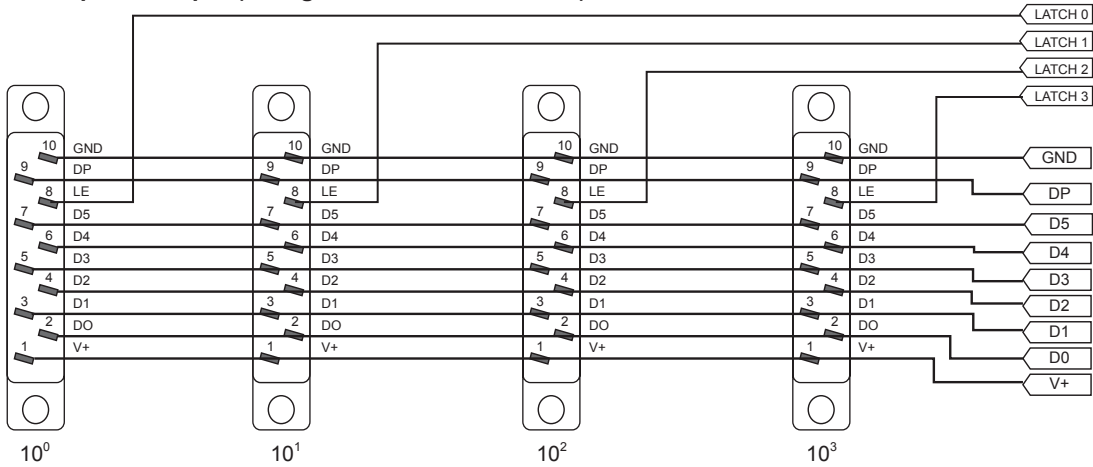

◎ Serial input: 4digit (wiring at rear side of this unit)

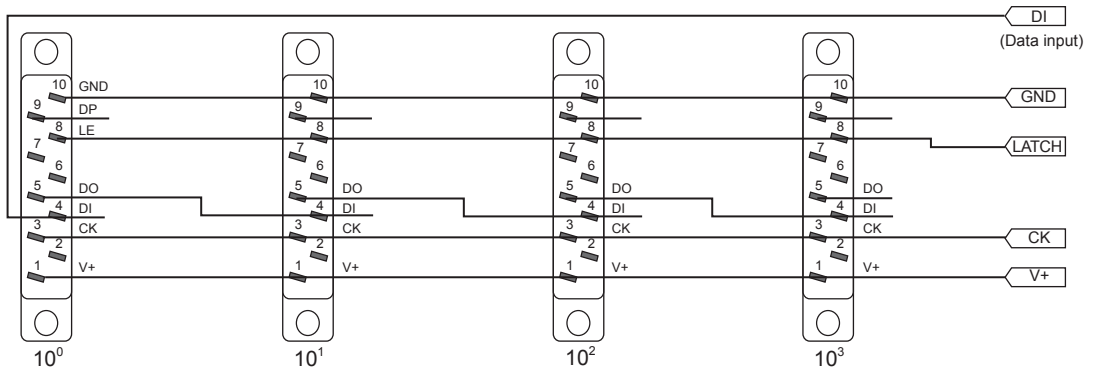

- (A) Photo-electric Sensors
- (B) Fiber Optic Sensors
- (C) Door/Area Sensors
- (D) Proximity Sensors
- (E) Pressure Sensors
- (F) Rotary Encoders
- (G) Connectors/ Sockets
- (H) Temperature Controllers
- (I) SSRs / Power Controllers
- (J) Counters
- (K) Timers
- (L) Panel Meters
- (M) Tacho / Speed / Pulse Meters
- (N) Display Units
- (O) Sensor Controllers
- (P) Switching Mode Power Supplies
- (Q) Stepper Motors & Drivers & Controllers
- (R) Graphic/ Logic Panels
- (S) Field Network Devices
- (T) Software

D1AA Series

■ The Application Of PLC Program (Serial Input Type)

1. Display unit: D1AA - □
2. Data transmission type: Serial input
3. Connection type: See serial connection type when using more than 2EA
4. Display result: "A" display
5. PLC: LSIS (LS Industrial Systems), Master-K Series
6. When using serial type, use transistor output card of PLC
7. Negative logic (NPN)

